

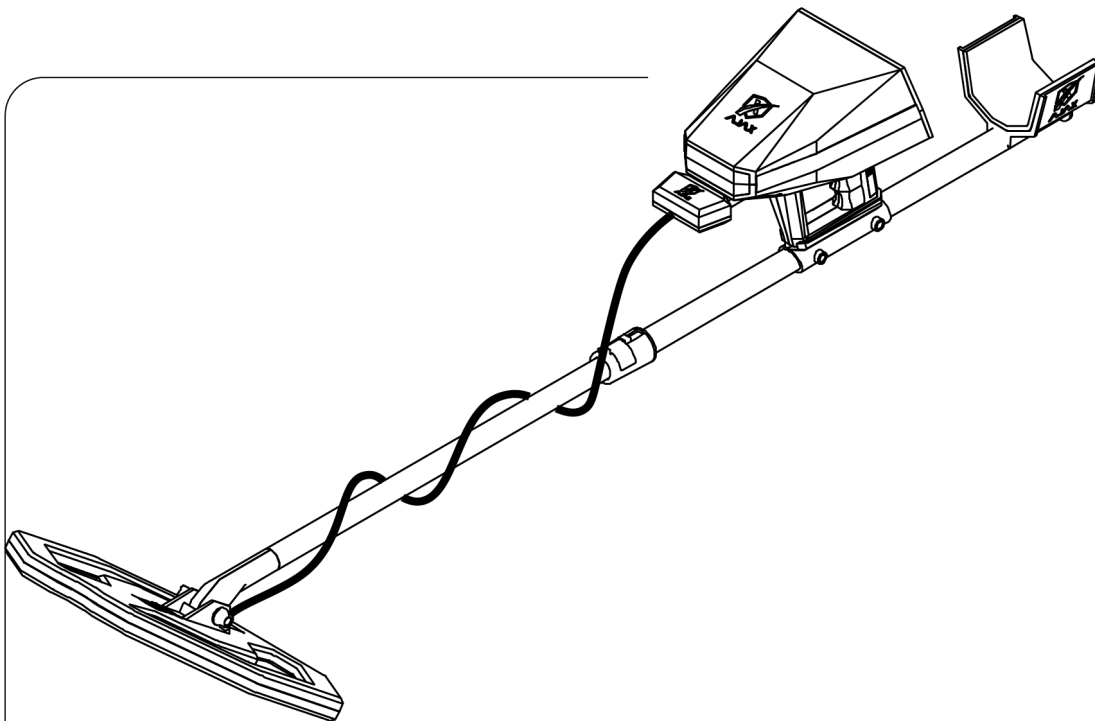

**AJAX**  
DETECTION TECHNOLOGY

User Manual



**AJAX**

DETECTION TECHNOLOGY

Se(g)ma

USER MANUAL

No part of this manual, including the products and software described in it, may be reproduced, transmitted, transcribed, stored in a retrieval system, or translated into any language in any form or by any means, except documentation kept by the purchaser for backup purposes, without the express written permission of AJAX DETECTION TECHNOLOGY LTD. (“AJAX”).

Product warranty or service will not be extended if: (1) the product is repaired, modified or altered, unless such repair, modification or alteration is authorized in writing by AJAX; or (2) the serial number of the product is defaced or missing.

AJAX PROVIDES THIS MANUAL “AS IS” WITHOUT WARRANTY OF ANY KIND, EITHER EXPRESS OR IMPLIED, INCLUDING BUT NOT LIMITED TO THE IMPLIED WARRANTIES FOR CONDITIONS OF MERCHANTABILITY OR FITNESS FOR A PARTICULAR PURPOSE. IN NO EVENT SHALL AJAX, ITS DIRECTORS, OFFICERS, EMPLOYEES OR AGENTS BE LIABLE FOR ANY INDIRECT, SPECIAL, INCIDENTAL, OR CONSEQUENTIAL DAMAGES (INCLUDING DAMAGES FOR LOSS OF PROFITS, LOSS OF BUSINESS, LOSS OF USE OR DATA, INTERRUPTION OF BUSINESS AND THE LIKE), EVEN IF AJAX HAS BEEN ADVISED OF THE POSSIBILITY OF SUCH DAMAGES ARISING FROM ANY DEFECT OR ERROR IN THIS MANUAL OR PRODUCT.

SPECIFICATIONS AND INFORMATION CONTAINED IN THIS MANUAL ARE FURNISHED FOR INFORMATIONAL USE ONLY, AND ARE SUBJECT TO CHANGE AT ANY TIME WITHOUT NOTICE, AND SHOULD NOT BE CONSTRUED AS A COMMITMENT BY AJAX. AJAX ASSUMES NO RESPONSIBILITY OR LIABILITY FOR ANY ERRORS OR INACCURACIES THAT MAY APPEAR IN THIS MANUAL, INCLUDING THE PRODUCTS AND SOFTWARE DESCRIBED IN IT.

Products and corporate names appearing in this manual may or may not be registered trademarks or copyrights of their respective companies, and are used only for identification explanation and to the owner’s benefit, without intent to infringe.

# Contents

Safety Information .....	5
Where to find more information .....	5
Introduction .....	6
Specification Summary.....	7
Package Contents.....	8
Package Contents.....	9
Overview .....	11
Hard Keys.....	12
Battery Assembly .....	14
Assembly .....	15
Search Coil Assembly.....	16
Initial setup.....	17
User Interface.....	18
Settings .....	19
Language.....	19
Time and Date .....	19
Display .....	20
Sound .....	21
Power Mode .....	22
Storage .....	23
Info.....	24
Security.....	25
Reset .....	26
Quick Settings .....	27
Search Coils.....	28
Smart Pulse.....	29
Spectrum Analyzer.....	33

Battery .....	37
Charging the battery .....	37
Precautions for operating environment .....	37
Battery charging tips and precautions .....	38
Contact Information .....	39
WEEE (Waste Electrical and Electronic Equipment) Statement .....	40

## Safety Information

The components included in this package are prone to damage from electrostatic discharge [ESD]. Please adhere to the following instructions to ensure successful device assembly.



Ensure that all components are securely connected. Loose connections may cause the device to not recognize a component or fail to start.

Hold the device firmly when assembling or operating.

It is recommended to discharge yourself of static electricity by touching another metal object before handling the device.

Store the device in an electrostatic free environment whenever the device is not in use.

Do not assemble or operate the device before reading the user manual. This might cause permanent damage to the components as well as injury to the user.



If you need help during installation step, please consult support via phone or Online help-desk.



Always turn off the device before storing the device.

Keep this user manual for future reference.



Keep this device away from humidity.

Make sure that your electrical outlet provides the same voltage as is indicated on the Charger before connecting to the electrical outlet.

All cautions and warning on the device and in the user

manual should be noted.

If any of the following situations arises, get the device checked by service personnel:

- Liquid has penetrated into the device.
- The device has been exposed to moisture.
- The device does not work well or you can not get it work according to user manual.
- The device has been dropped or damaged.
- The device has obvious sign of breakage.

Do not leave the device in an environment above 60°C (140°F), it may damage the device.



## Where to find more information

Refer to the following sources for additional information and for product and software updates.

### 1. AJAX websites:

The AJAX website provides updated information on AJAX hardware and software products. Refer to the AJAX contact information.

### 2. Optional documentation:

Your product package may include optional documentation, such as warranty fliers, that may have been added by your dealer. These documents are not part of the standard package.

## Introduction

SEGMA detects and finds targets that were previously hard to find. This device detects up to 8 meters underground while many other devices cannot reach these depths. SEGMA responds to targets immediately and shows the results, and it has a comprehensive interface that allows the user to work on the device easily without any complications that exhausts the search process.

The ease of use of SEGMA makes it flexible, fast-moving and a configurable device with a very powerful display to show the results. It works through two different detection systems to animate and visualize results and data.

1- Smart Pulse (Pulse Induction)

2- Spectrum Analyzer (3D)

Thank you for purchasing the AJAX SEGMA detection device.

This quick Start section provides demonstration about how to assemble your device .

Some of the installations also provide video demonstrations. Please link to the URL to watch it with the web browser on your phone or tablet. You may have even link to the URL by scanning the QR code.

## Specification Summary

AJAX Detection Technology has been working on an innovation in detection field to expand the horizons and opportunities for new experience leading to efficient work-flow.

Research Principle	Multi-detection systems and functions, contains 2 optional systems
Operating Principle	Processing data and digital signals and converting them to visual and audible results
Processor Architecture	MIPS 32
Operation processor	M4K™ Core
Display Screen	TFT Color LCD, 800 x 480 WVGA, 16-bit color depth
Battery	7.4 volts, 3300 mAh
Power Rating	400 mA
Battery Endurance	Typical usage time 5 hours*
Power Adapter	240-100 VAC / 15 VDC - EU Plug
Storage	1 GB / it can save to 1000 scans.
Sound	High quality sounds, 32 KBIT/S, MP3
Notifications	Sound and tactile feedback configurable in the settings menu for
Bluetooth	2.4 GHz, sensitivity up to -80dBm.
Languages	Multilingual User Interface with support for 8 languages.
Date and Time	Real Time Clock
Login Restriction	Configurable PIN.
Dimensions	145x45x24 cm
Overall Dimensions	82x52x20 cm
Package Total Weight	6.5 kg
Assembly Weight	1.5 Kg (~3 lbs) ; 2.2 Kg (~4.9 lbs).
Operating temperature	From -10° C to 60° C (14° F - 140° F)
Storage temperature	From -10° C to 80° C (14° F - 176° F)
Humidity	Could be stored and operated at relative humidity level up to 90%.

\*- Typical battery endurance is subjected to battery life degradation and environmental factors.



# Package Contents

---

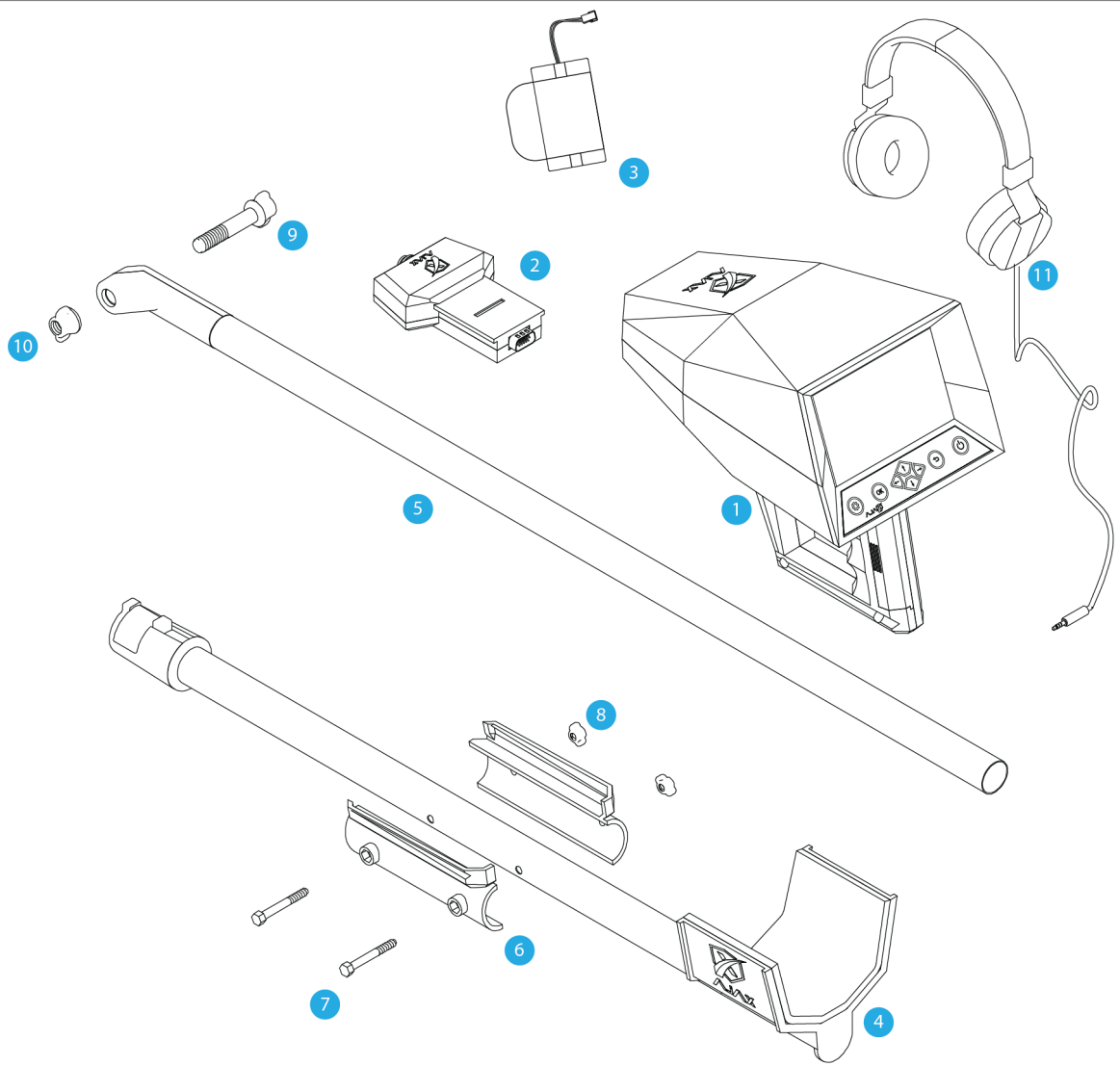

# Package Contents

---

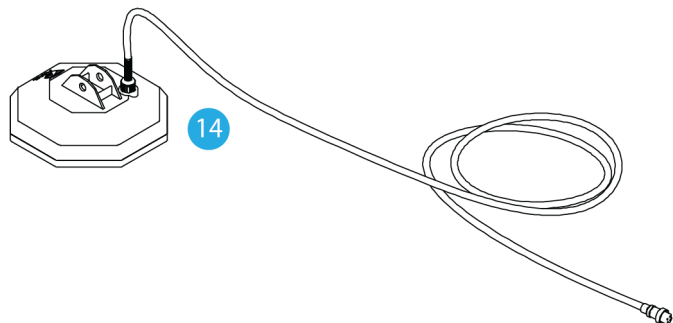
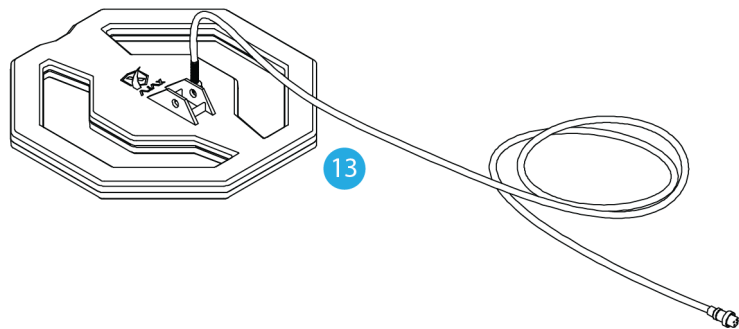
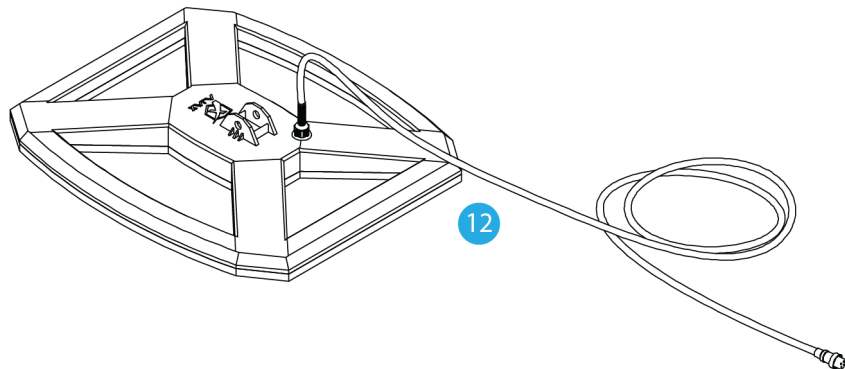

## Package Contents

---

Check your device package for the following items:

1	Main Unit
2	Connection Module
3	Battery Pack
4	Carrying Pole
5	Extension Pole
6	Device Clamp
7	Clamp Bolt x2
8	Clamp Nut x2
9	Bolt
10	Nut
11	Headphones
12	C3 Search Coil
13	C2 Search Coil
14	C1 Search Coil

- The items supplied with the device and any available accessories may vary depending on the region or service provider.
- The supplied items are designed only for this device and may not be compatible with other devices.
- Appearances and specifications are subject to change without prior notice.
- You can purchase additional accessories from your local AJAX retailer. Make sure they are compatible with the device before purchase.
- Use only AJAX-approved accessories. Using unapproved accessories may cause the performance problems and malfunctions that are not covered by the warranty.
- Availability of all accessories is subject to change depending entirely on manufacturing companies. For more information about available accessories, go to the AJAX website.

## Overview

---

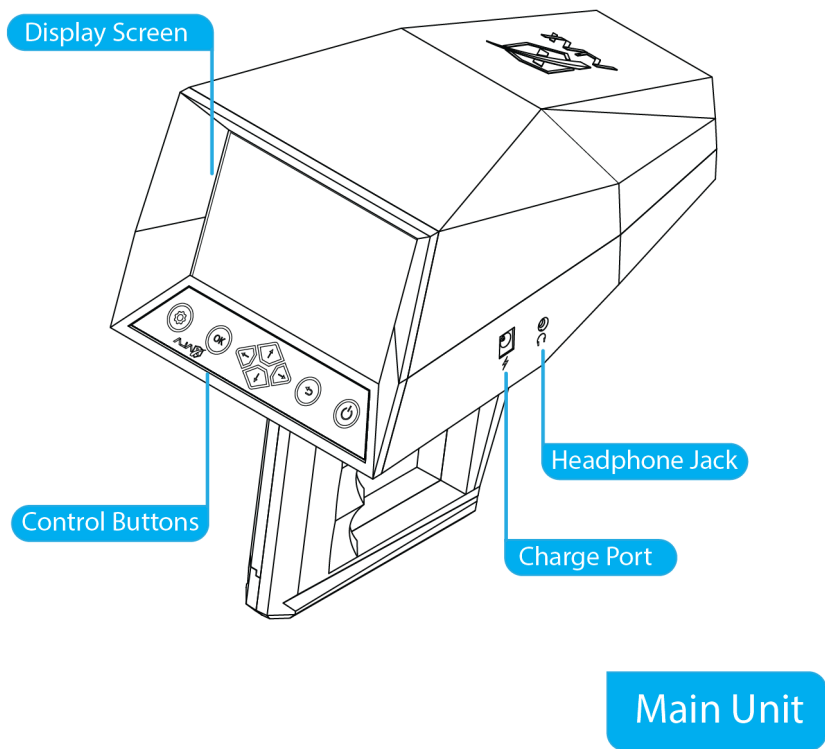

# Hard Keys

---

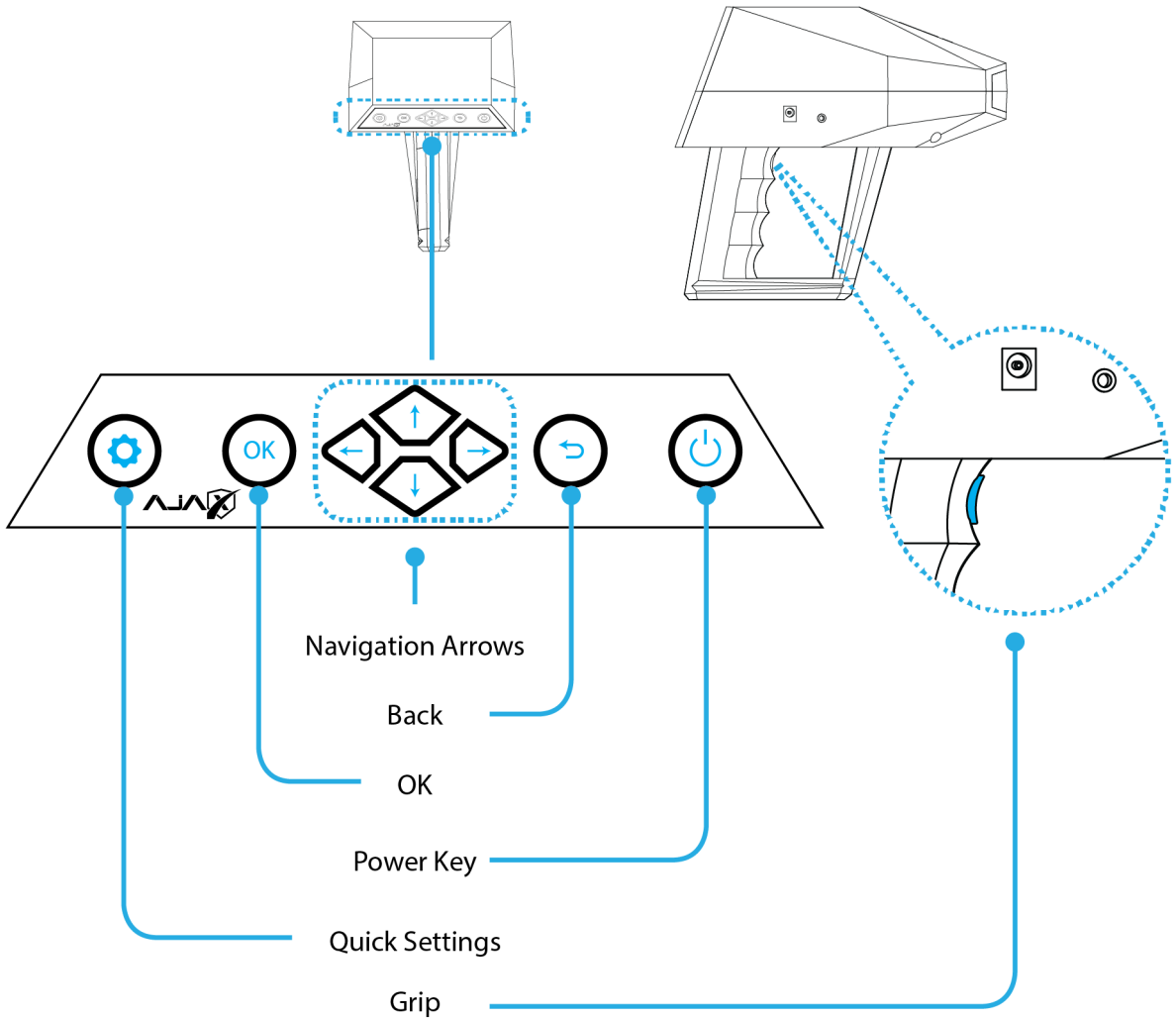

## Hard Keys

---

Key	Function
Power	<ul style="list-style-type: none"><li>• Press and hold to turn the device on or off.</li><li>• Press to turn on or lock the screen.</li></ul>
OK	<ul style="list-style-type: none"><li>• Confirm/enter the selected option.</li></ul>
Back	<ul style="list-style-type: none"><li>• Go to previous menu, cancel.</li></ul>
Navigation Keys	<ul style="list-style-type: none"><li>• Navigation through the device interface.</li></ul>
Quick Settings	<ul style="list-style-type: none"><li>• Press to drop the quick settings menu.</li></ul>
Grip Key	<ul style="list-style-type: none"><li>• Multi-purposed key for ease of access while searching.</li></ul>

### Turning the device on and off

Press and hold the Power key for a few seconds to turn on the device.

When you turn on your device for the first time or after performing a data reset, follow the on-screen

Instructions to set up your device.

To turn off the device, press and hold the Power key, and then tap Power off.

Follow all posted warnings and directions from authorized personnel in areas where the use of wireless devices is restricted, such as airplanes and hospitals.

# Battery Assembly

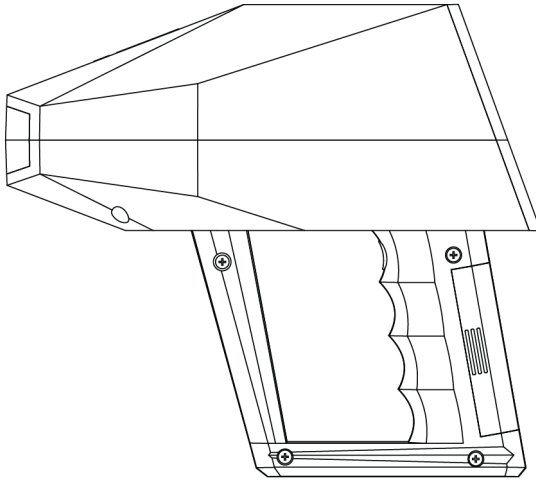
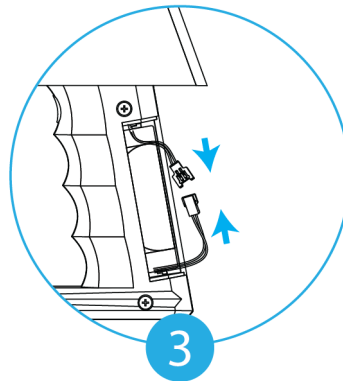
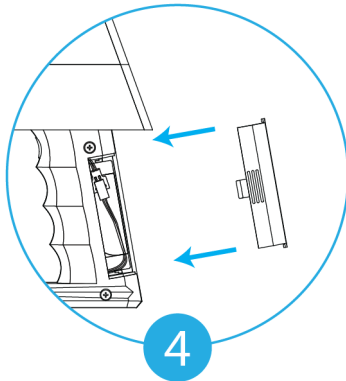
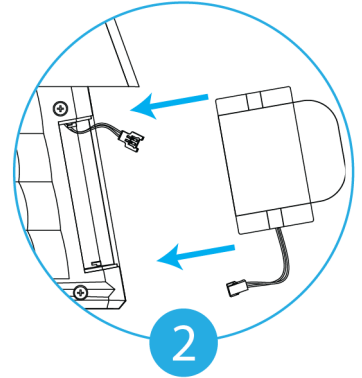
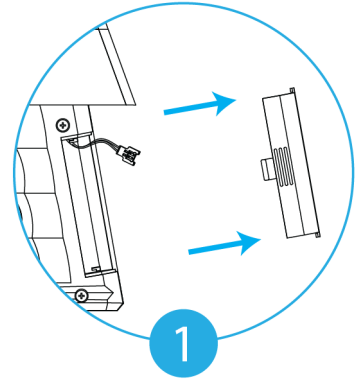

figure 1 -Battery Assembly



- 1- Press firmly at the ridges and push outwards to remove the battery cover.
- 2- Insert the battery pack inside the compartment.
- 3- Connect the wires and make sure they are securely attached.
- 4- Insert the connector inside the compartment and put the cover back on the grip.

# Assembly

---

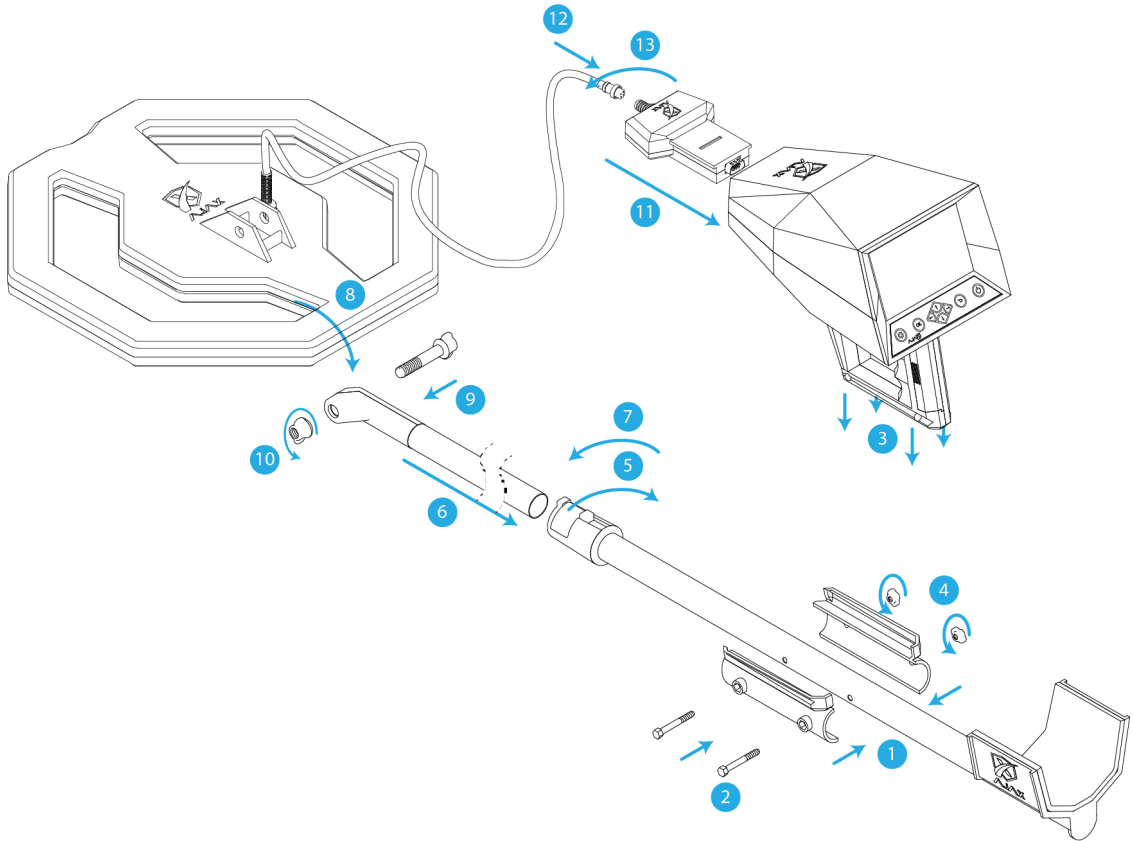

figure 2 - Search Coil Assembly



## Assembly

### Search Coil Assembly

- 1- Align the clamp with the holes on the pole.
- 2- Insert the screws into the clamp.
- 3- Put the Main Unit inside the clamp.
- 4- Put the nuts on the screws and tighten them.
- 5- Unlatch the pole lock.
- 6- Insert the second pole and adjust the length.
- 7- Lock the latch back in securely.
- 8- Align the Search Coil with the second pole tip.
- 9- Insert the screw.
- 10- Adjust the Search Coil angle and tighten the nut.
- 11- Inset the connection module in front of the main unit.
- 12- Wrap the cable around the second pole
- 13- Insert the connector into the connection module in the front of the Main Unit and tighten it .

## Initial setup

When you turn on your device for the first time or after performing a data reset, follow the on-screen instructions to set up your device.

- The initial setup procedures may vary depending on the device's software and your region.

1 Turn on the device.

Press and hold to turn the device on

2 Select a language.

Select your preferred device language and select .

3 Set Time and Date.

Press   to move, and  to change values.

After setting the parameters the Main Menu will show on the display.



*Note:*

The time format is 24h (hh:mm) e.g. 19:42

The date format is day/month/year (DD/MM/yyyy) e.g. 30/03/2018.

# User Interface

---

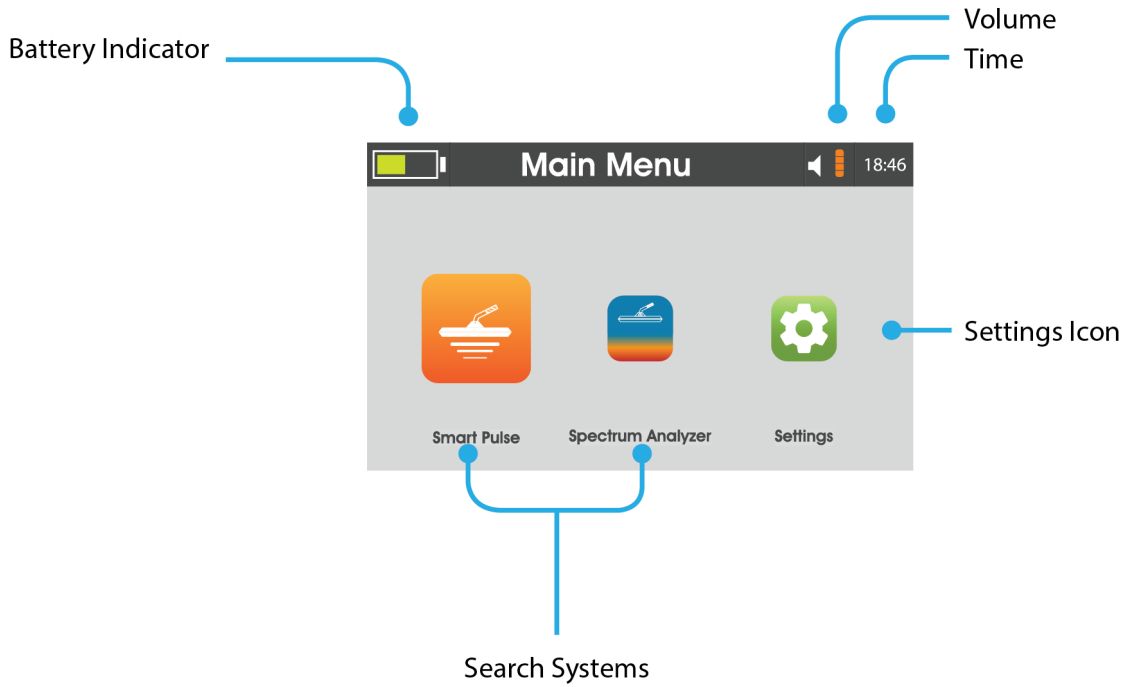

# Settings

---



## Language

The device supports 8 different languages for the interface (English, French, German, Spanish, Italian, Russian, Turkish and Arabic)

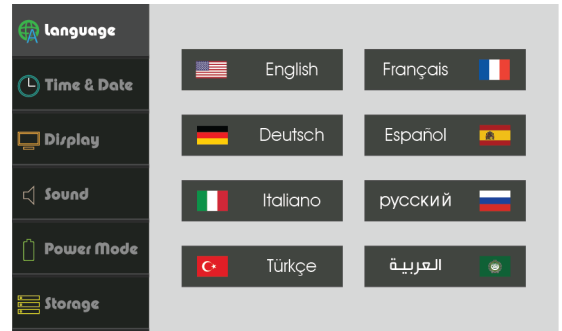
Select language and press  to set the language to the device.



## Time and Date

Press   to move, and  to change values.

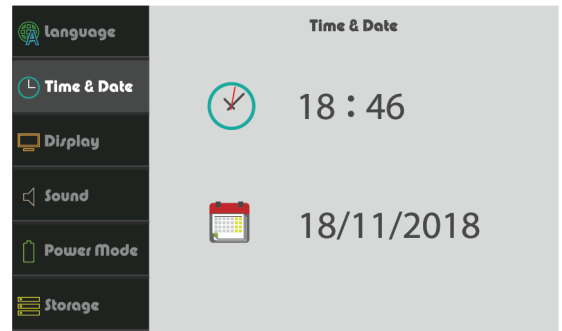

*Note:*

The time format is 24h (hh:mm) e.g. 19:42

The date format is day/month/year (DD/MM/yyyy) e.g. 30/03/2019.

# Settings

---

## Display

Brightness:

Move the brightness slider to adjust the brightness.  
The value is adjustable from 0 to 100% brightness in a 1% increments.  
Maximum brightness is 250 nits.



Sleep Mode:





Set the automatic dimming for the brightness in order to preserve power.

This setting could be set to 15, 30, 45 or 60 seconds, or it could be turn off completely.

# Settings



---

## Sound

Press   to move the cursor, press   to change values, and press  to change mode.

### I- General Volume:

This setting controls the volume for the notifications, errors, and the starting audio.

To set volume press  , and press  to change mode.

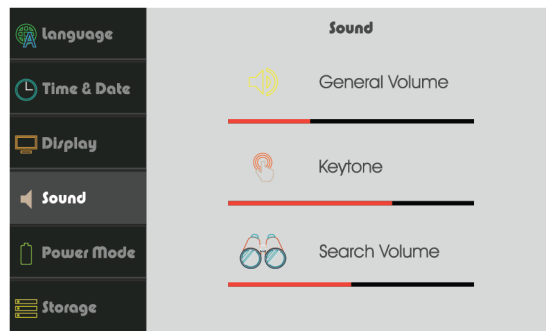

#### 1- General mode

The device will respond with vibration in addition to sound.



#### 2- Silent mode

The device will not respond with any type of feedback



#### 3- Vibration mode

The device will only respond with vibration feedback



#### 4- Normal mode

The device will only respond with sound feedback

### II- Key-tone:

This setting controls the volume for the feedback of pressing the buttons.

To set volume press  .

### III- Search Volume:

This setting controls the volume for search results and readings.

To set volume press  .



### Note:

*The key-tone volume and search volume are not set by the general volume.*

# Settings

---

## Power Mode

This menu shows the power state of the device and current power mode, to change power mode move the cursor   and press  to confirm.

*I- Power Saving mode:*



This mode saves power by disabling idle modules in order to preserve power for long search operations.

*II- Optimum Mode:*



This mode will set the device with all modules on for a steady performance operation.

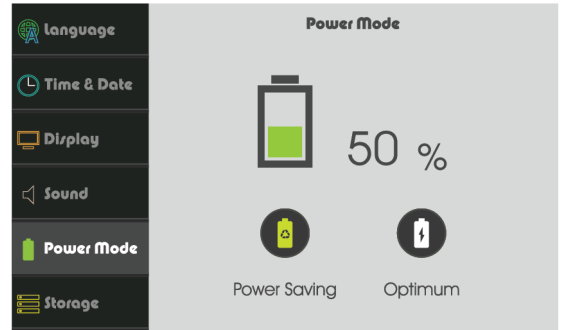



# Settings

---

## Storage

This menu shows the previously saved search results.

The user can view or delete the results.

Press   to select which system results to show.

Then the results list shows the saved searches

Navigate the list and press  to view or delete the highlighted result.

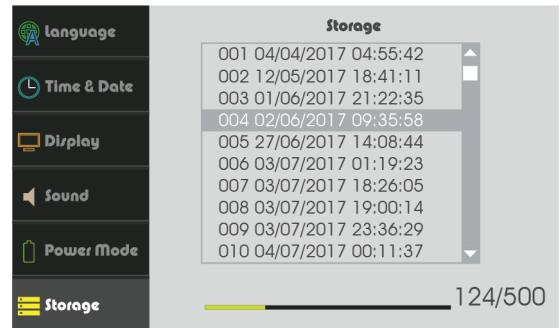
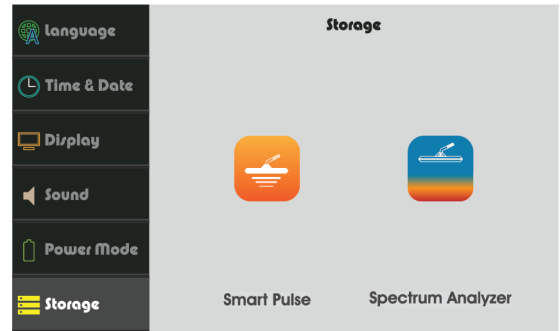



# Settings

---

## Info

This menu shows:

Device Version  
Software Version  
Model  
Uptime

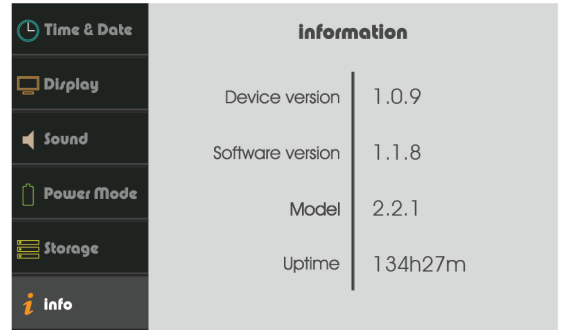



# Settings

---

## Security

This menu shows Secure Start state.

To change state press   then  or  to activate .

To change state navigate to the toggle and press ,  to activate or  to deactivate.

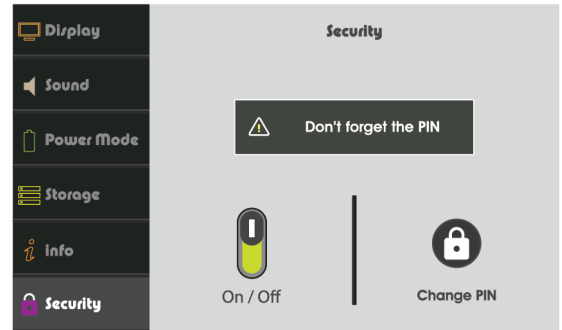

Enter a new PIN then press .

Enter the PIN again for confirmation.

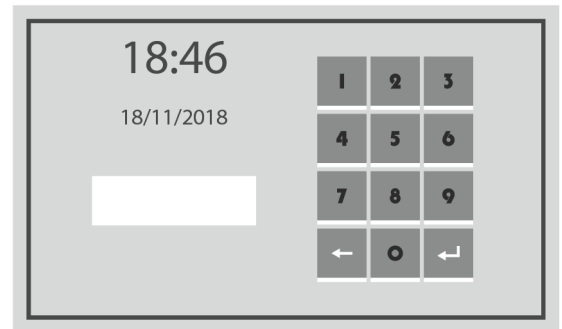

# Settings

---

## Reset

This menu shows the reinitializing options.

### *I- Clear Memory:*

This option erase all saved results from memory.

### *II- Reset settings:*

This option resets all the settings to default values.

### *III- Factory Reset:*

This option resets all the settings to default values and erase all saved results.

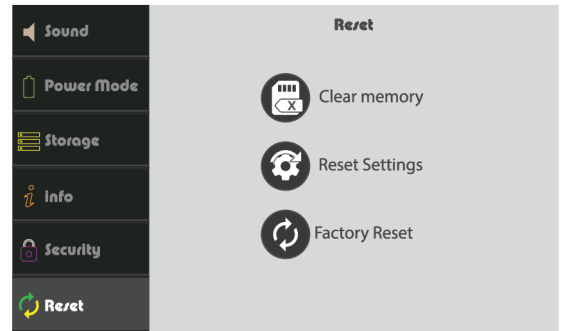





## Quick Settings

---



To access the quick settings menu, press  key on the far left of the keypad.

When pressed, the title in the status bar will be replaced with the settings icons.

Press   to navigate through the options.







 Display Brightness. It can be set by pressing  to decrease or  to increase the brightness intensity.



 Sleep mode. It can be set to 5 settings 15, 30, 45 or 60 seconds or be set off completely.



 Power mode. It can be set by pressing  to change the power mode into:

 Optimum mode

 Power save mode

 Sound. Press  to increase or  to decrease the current value, while pressing  will change the sound value for the device keys  or the search .

"18:46" Time. Set the current time by pressing  or .

*Note: To exit the quick settings menu press  or . The quick settings menu is accessible in every menu with a visible status bar.*

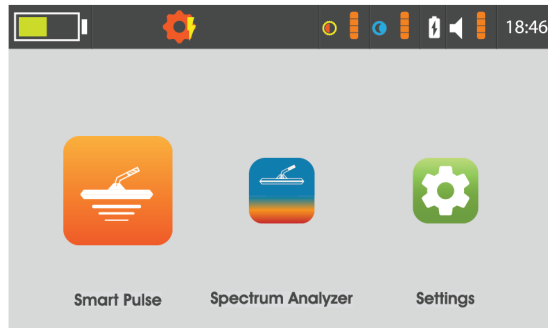

## Search Coils

---



C1 Search coil provides the required accuracy for the device to pick up on small and tiny objects and targets. With its light weight and small footprint it is the best tool for long search and tracking processes.



C2 Search coil is the balance between depth and sense, making it the ideal search for different terrains and search areas whether the objects are located deep in ground or closer to surface without losing the signal strength or sense.



C3 Search coil is the depth tool for this device with its rectangular design it covers more surface area with extended depths of search to locate large and deep target.

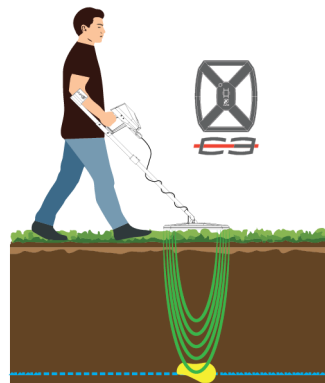
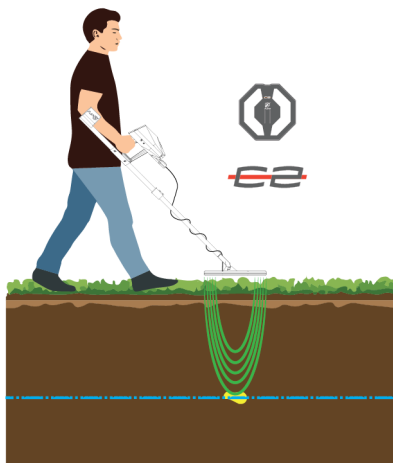
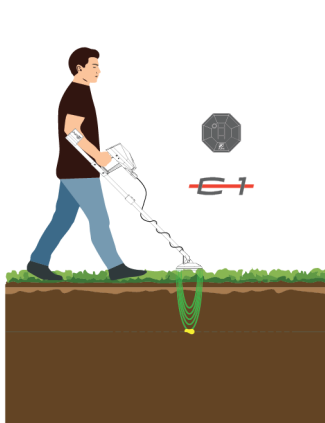

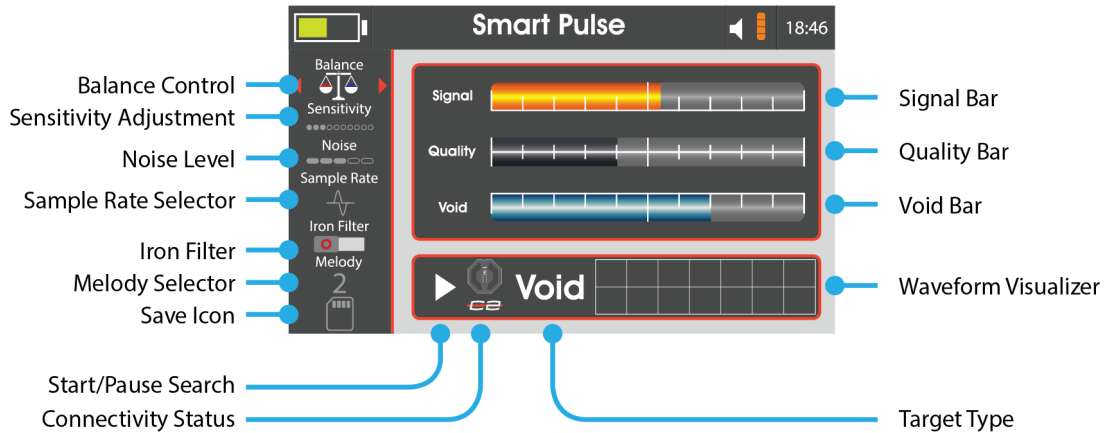

## Smart Pulse



Assemble the device as shown in “figure 2 -Search Coil Assembly” on page 16  
Select Smart Pulse from the Main Menu.  
The device shows the search interface which contains:

### Balance Control:

Press  to reset the bars to the initial values and balance them on the ground. The balance can be further adjusted by pressing   for fine tuning and more control over the balance process.

### Sensitivity Adjustment:

This adjustment sets the device respond to small or deep target, so it is recommended to increase it as long as the signal is stable.

### Noise Level:

It controls the quality of the signal. It is also recommended to be increased as long as the bars are stable.

### Sample Rate Selector:

This setting adjusts the number of samples taken to process. It does not need a change from its initial value unless there is another device in the search area.

### Iron Filter:

This setting disable the audio feedback for the iron based metals. So the user can ignore these kinds of targets.

## Smart Pulse

---

### Melody Selector:

Selects the audio feedback melody of the device.

### Save Icon:

Press  to save the values shown on the screen into storage for further review.

### Signal Bar:

This bar fills when the pulse from the search coil is further induced by a target. The larger or closer the target is the more the bar fills.

### Quality Bar:

This shows the quality of the signal received, if the quality of the signal is high enough then the device will process the target type accordingly.

### Void Bar:

This shows the induced signal by underground hollow pockets and cavities/voids.

### Target Type:

Shows the detected signal type for the target.

### Waveform Visualizer:

It stores and shows the recent activity of the search.

### Connectivity Status:

This icon displays the current attached search coil or if there is disconnection in the connection module or the search coil.

### Start/Pause Search:

Press the Grip key to Pause/Start the search.

#### *Note:*





The device needs to be rebalanced after adjusting any of the parameters.

## Smart Pulse

---

Hold the device as shown in the figure on right.

Put the search coil on the ground and press the Grip key to start the search.

The device needs to be balanced first. To balance the device press  over  so the bars on the right are all reset to the initial values. If a static signal is still picked up by the device it can be fine tuned by pressing   over .

Once the device is balanced and all the bars on the right are empty, lift the device 3-5 cm off the ground and move it over the search area in a sweeping motion left and right in a medium pace. Keep the search coil parallel to the ground during the search for maximum performance and accurate results.

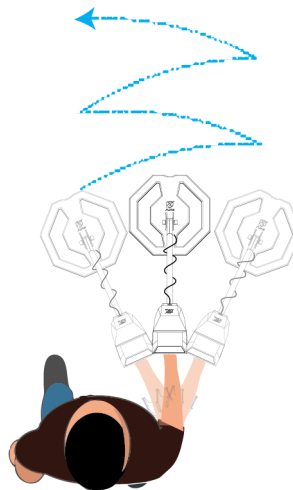
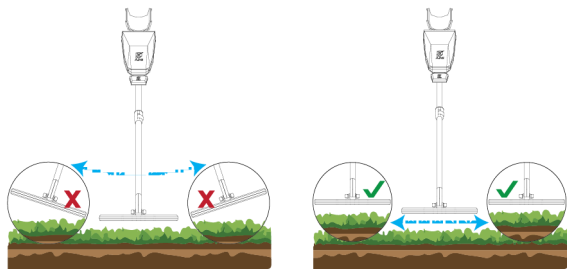



## Smart Pulse

---

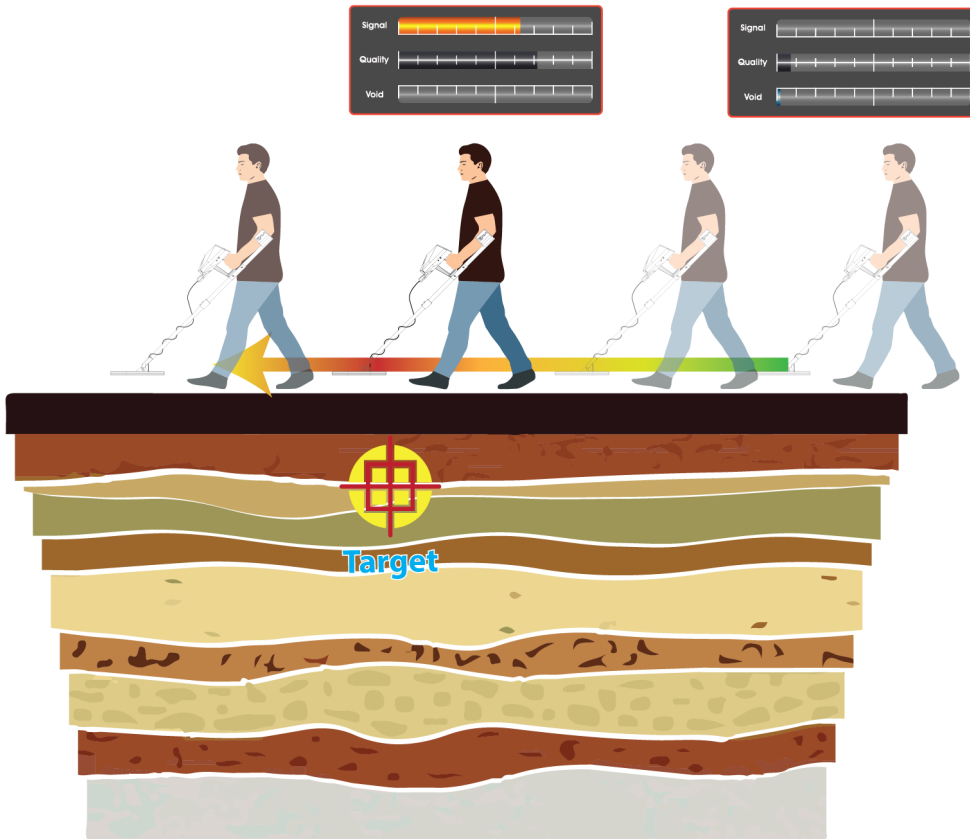

While moving over the scan area track the changes on the display in the Signal, Quality and Void levels and reading intensity to enclose targets.

Change the sensitivity or balance to fine-tune the device to meet the desired configuration.

## Spectrum Analyzer

This system takes a criss-cross reading of the target and analyze the data then visualizes the result in a 3D plotted surface on the interface representing the depth and signal strength over the search area.

Assemble the device as shown in “figure 2 -Search Coil Assembly” on page 16.

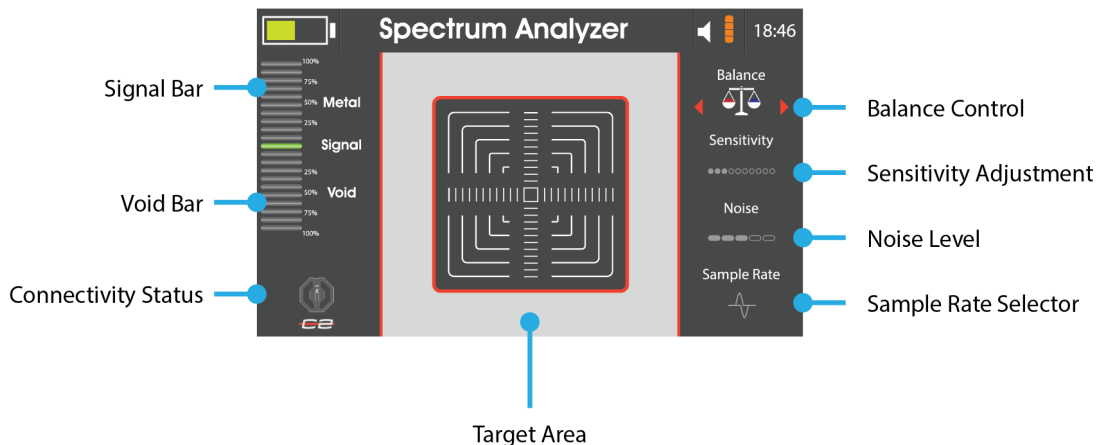

Select Spectrum Analyzer from the Main Menu.



## Spectrum Analyzer

---

### Balance Control:

Press  to reset the bars to the initial values and balance them on the ground. The balance can be further adjusted by pressing   for fine tuning and more control over the balance process.

### Sensitivity Adjustment:

This adjustment sets the device respond to small or deep target, so it is recommended to increase it as long as the signal is stable.

### Noise Level:

It controls the quality of the signal. It is also recommended to be increased as long as the bars are stable.

### Sample Rate Selector:

This setting adjusts the number of samples taken to process. It does not need a change from its initial value unless there is another device in the search area.

### Signal Bar:

This bar fills when the pulse from the search coil is further induced by a target. The larger

or closer the target is the more the bar fills.

### Void Bar:

This shows the induced signal by underground hollow pockets and cavities/voids.

### Connectivity Status:

This icon displays the current attached search coil or if there is disconnection in the connection module or the search coil.

#### Note:

If a Smart Pulse search was conducted prior to the Spectrum Analyzer, the Sensitivity, Noise and Sample Rate values are carried into Spectrum Analyzer from the Smart Pulse system.

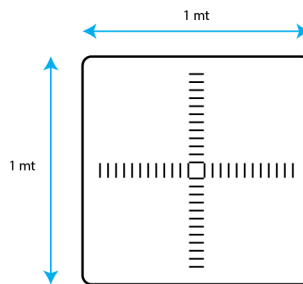

The device needs to be rebalanced after adjusting any of the parameters.

The Target area is optimized to be 1 meter by 1 meter.



## Spectrum Analyzer

Adjust the balance so the device is idle out of the target area.

Press the grip key to move to the target area. Select the starting position by pressing . Put the search coil at the edge of the target area and press  and move the search coil over the target area as it shown on the interface.

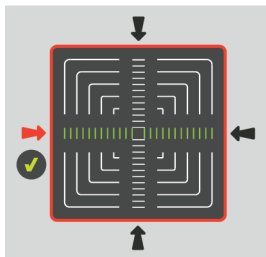
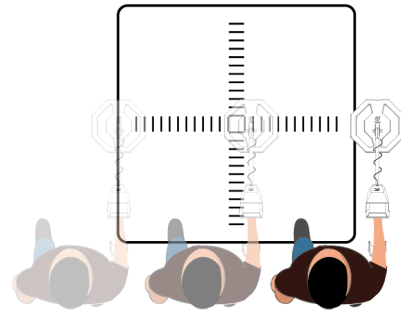
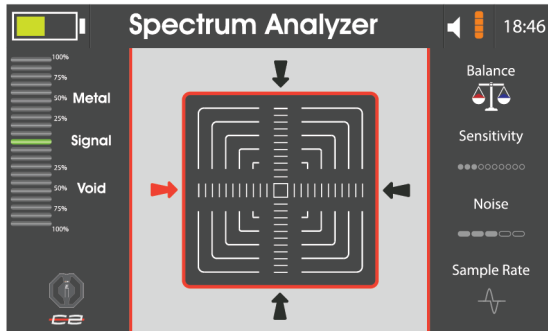
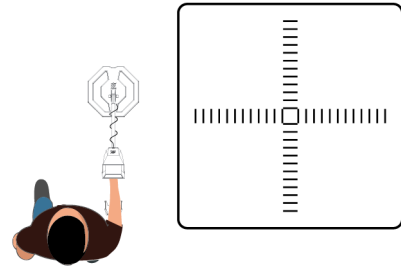

## Spectrum Analyzer

Repeat the process for all the sides.  
Once all the readings are taken the device will process them into a final 3D plotted surface representing the Signal strength and width.

The final result interface shows the target type and estimated depth.

Then the user can save the result or restart the scan again.

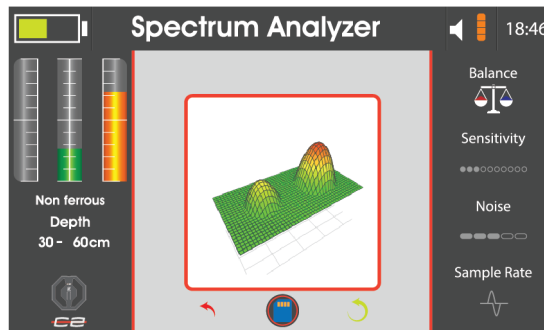
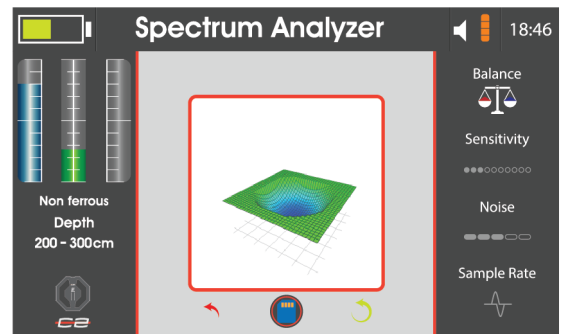
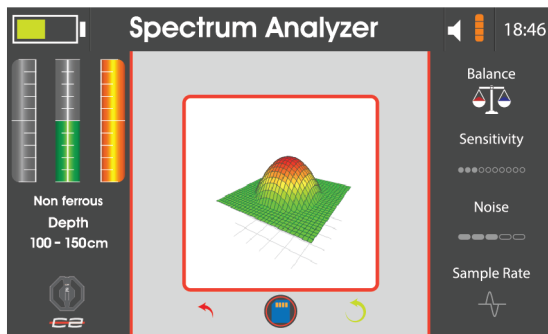
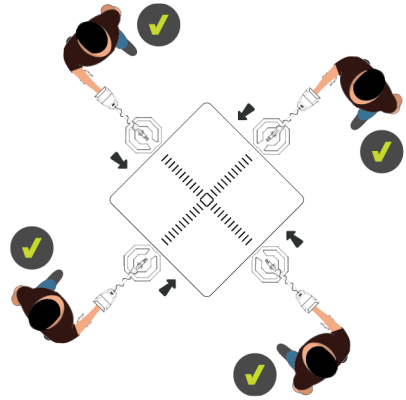

# Battery

---

## Charging the battery

Charge the battery before using it for the first time or when it has been unused for extended periods.

Use only AJAX-approved chargers, batteries, and cables.

Unapproved chargers or cables can cause the battery to explode or damage the device.

- Connecting the charger improperly may cause serious damage to the device.

Any damage caused by misuse is not covered by the warranty.

- Use only cable supplied with the device. The device may be damaged if you use different cable.

To save energy, unplug the charger when not in use.

The charger does not have a power switch, so you must unplug the charger from the electric socket when not in use to avoid wasting power.

The charger should remain close to the electric socket and easily accessible while charging.

**1** Plug the DC cable into the device's Charge jack.

**2** Plug the power adapter into an electric socket.

**3** After fully charging, disconnect the charger from the device.

Then, unplug the charger from the electric socket.

## Precautions for operating environment

Your device may heat up due to the environment in the following conditions.

Use caution to avoid shortening the battery's lifespan, damaging the device, or causing a fire.

- Do not store your device in very cold or very hot temperatures.
- Do not expose your device to direct sunlight for extended periods.
- Do not use or store your device for extended periods in very hot areas, such as inside a car in the summertime.
- Do not place the device in any areas that may overheat, such as on an electric heating mat.
- Do not store your device near or in heaters, microwaves, hot cooking equipment, or high pressure containers.
- Never use a damaged charger or battery.

# Battery

---

## Battery charging tips and precautions

- When the battery power is low, the battery icon appears empty.
- If the battery is completely discharged, the device cannot be turned on immediately when the charger is connected. Allow a depleted battery to charge for a few minutes before turning on the device.
- The device can be used while it is charging, but it may take longer to fully charge the battery.
- If the device receives an unstable power supply while charging, the device may not function. If this happens, unplug the charger from the device.
- While charging, the device and the charger may heat up. This is normal and should not affect the device's lifespan or performance. If the battery gets hotter than usual, the charger may stop charging.
- If the device is not charging properly, take the device and the charger to AJAX or an AJAX Authorized Service Centre.

## Contact Information

---

### AJAX DETECTION TECHNOLOGY LTD.

Address 1201 N.W. Briarcliff Parkway, 2nd Floor,  
Kansas City, Missouri, 64116 USA

Telephone +1 816 298 0485  
+1 816 399 3744

E-mail [info@ajaxdetection.com](mailto:info@ajaxdetection.com)  
Web site <http://www.ajaxdetection.com>



## WEEE (Waste Electrical and Electronic Equipment) Statement

---

To protect the global environment and as an environmentalist, AJAX must remind you that... Under the European Union ("EU") Directive on Waste Electrical and Electronic Equipment, Directive 2002/96/EC, which takes effect on August 13, 2005, products of "electrical and electronic equipment" cannot be discarded as municipal waste anymore, and manufacturers of covered electronic equipment will be obligated to take back such product at the end of their useful life. AJAX will comply with the product take back requirements at the end of life of AJAX-branded products that are sold into the EU. You can return these products to local collection points.

### Environmental Policy

The product has been designed to enable proper reuse of parts and recycling and should not be thrown away at its end of life.

Users should contact the local authorized point of collection for recycling and disposing of their end-of-life products.

Visit the AJAX website and locate a nearby distributor for further recycling information.

Users may also reach us at <envo@ajaxdetector.com> for information regarding proper Disposal, Take-back, Recycling, and Disassembly of AJAX products.

European Union:



Batteries, battery packs, and accumulators should not be disposed of as unsorted household waste. Please use the public collection system to return, recycle, or treat them in compliance with the local regulations.

Taiwan:

廢電池請回收



For better environmental protection, waste batteries should be collected separately for recycling or special disposal.

California, USA:



The button cell and Li-ion battery may contain perchlorate material and requires special handling when recycled or disposed of in California.

For further information please visit:

<http://www.dtsc.ca.gov/hazardouswaste/perchlorate/>





**AJAX**  
DETECTION TECHNOLOGY

[www.ajaxdetector.com](http://www.ajaxdetector.com)